

A-Y3H Series

■ Three-phase Induction Motor



A-Y3H SERIES

THREE-PHASE INDUCTION MOTOR



PRODUCT INFORMATION

A-Y3H Series motor is designed by Alliance Motori, and has obtained the national layout-design invention patent. This series motor has beautiful profile, high efficiency, low noise and vibration. It can be used to drive the equipment of the fans, pumps, machine tools, compressors, transportation and so on, and can also be used in the hazardous areas with oil and chemical, steel paints, mining industry. A-Y3H series motor adopt good cold-rolled steel, it is the entirely refreshed generation products aimed to replace the Y, Y2 and Y3 series motor, with IP55 protection degree class F insulation and the same dimensions according to IEC 60072.

SPECIFICATION

Standard | GB/T 25290, IEC60034-30
Frame Size | H80-355mm
Rated Power | 0.18kW-315kW
Degrees or Energy Efficiency | IE1
Voltage and Frequency | 380V / 50Hz
Degrees of Protections | IP55
Degrees of Insulation / Temperature Rise | F/B
Installation Methods | B3/B5/B35/V1
Ambient Temperature | -15°C ~+ 40°C
Relative Humidity Should Be Less Than 90%
Altitude Should Be Lower Than 1000m
Above Sea Level
Cooling Method | IC416, IC411

Note. Data May Change Without Notice

2-Pole, 3000 r/min Synchronous Speed

380V 50Hz

Motor Type	Rated Power	Rated Speed	Rated Current	Rated Eff.	Power Factor	Rated Torque	Ist In	Tst Tn	Tmax Tn	Tmin Tn	LW	LW	Net Weight Kg
	kW	r/min	A	η %	cos φ	Nm					dB(A) no load	dB(A) load	
80M1-2	0.75	2840	1.8	75.0	0.83	2.5	6.1	2.2	2.3	1.5	67	69	16
80M2-2	1.1	2840	2.6	76.2	0.84	3.7	6.9	2.2	2.3	1.5	67	69	17
90S-2	1.5	2850	3.5	78.5	0.84	5	7.0	2.2	2.3	1.5	72	74	20
90L-2	2.2	2850	4.9	81.0	0.85	7.4	7.0	2.2	2.3	1.4	72	74	25
100L-2	3	2880	6.3	82.6	0.87	10	7.5	2.2	2.3	1.4	76	78	30
112M-2	4	2880	8.2	84.2	0.88	13.3	7.5	2.2	2.3	1.4	77	79	38
132S1-2	5.5	2900	11.1	85.7	0.88	18.1	7.5	2.2	2.3	1.2	80	82	57
132S2-2	7.5	2900	14.9	87.0	0.88	24.5	7.5	2.2	2.3	1.2	80	82	60
160M1-2	11	2930	21.2	88.4	0.89	35.8	7.5	2.2	2.3	1.2	86	88	100
160M2-2	15	2930	28.6	89.4	0.89	48.8	7.5	2.2	2.3	1.2	86	88	110
160L-2	18.5	2930	34.7	90.0	0.90	60.4	7.5	2.2	2.3	1.1	86	88	125
180M-2	22	2940	41	90.5	0.90	71.4	7.5	2.0	2.3	1.1	89	91	175
200L1-2	30	2950	55.4	91.4	0.90	97.2	7.5	2.0	2.3	1.1	92	94	225
200L2-2	37	2950	67.9	92.0	0.90	120	7.5	2.0	2.3	1.1	92	94	245
225M-2	45	2970	82.1	92.5	0.90	145	7.5	2.0	2.3	1.0	92	94	280
250M-2	55	2970	99.8	93.0	0.90	177	7.5	2.0	2.3	1.0	93	95	380
280S-2	75	2970	135	93.6	0.90	241	7.0	2.0	2.3	0.9	94	96	510
280M-2	90	2970	160	93.9	0.91	290	7.1	2.0	2.3	0.9	94	96	580
315S-2	110	2980	195	94.0	0.91	353	7.1	1.8	2.2	0.9	96	98	850
315M-2	132	2980	233	94.5	0.91	423	7.1	1.8	2.2	0.9	96	98	945
315L1-2	160	2980	282	94.6	0.91	513	7.1	1.8	2.2	0.9	99	101	1020
315L2-2	200	2980	348	94.8	0.92	641	7.1	1.8	2.2	0.8	99	101	1180
355M-2	250	2980	434	95.2	0.92	802	7.1	1.6	2.2	0.8	103	105	1740
355L-2	315	2980	545	95.4	0.92	1010	7.1	1.6	2.2	0.8	103	105	1900

Note. Data May Change Without Notice

PERFORMANCE PARAMETERS

A-Y3H SERIES

4-Pole, 1500 r/min Synchronous Speed

380V 50Hz

Motor Type	Rated Power	Rated Speed	Rated Current	Rated Eff.	Power Factor	Rated Torque	I_{st}	T_{st}	T_{max}	T_{min}	LW	LW	Net
	kW	r/min	A	η %	$\cos \phi$	Nm	In	Tn	Tn	Tn	dB(A) no load	dB(A) load	Weight Kg
80M1-4	0.55	1390	1.6	71.0	0.75	3.8	5.2	2.4	2.3	1.7	58	63	17
80M2-4	0.75	1390	2.1	73.0	0.76	5.2	6.0	2.3	2.3	1.6	58	63	18
90S-4	1.1	1400	2.8	76.2	0.77	7.5	6.0	2.3	2.3	1.6	61	66	20
90L-4	1.5	1400	3.7	78.5	0.78	10.2	6.0	2.3	2.3	1.6	61	66	23
100L1-4	2.2	1420	5.1	81.0	0.81	14.8	7.0	2.3	2.3	1.5	64	69	30
100L2-4	3	1420	6.7	82.6	0.82	20.2	7.0	2.3	2.3	1.5	64	69	35
112M-4	4	1440	8.8	84.2	0.82	26.5	7.0	2.3	2.3	1.5	65	70	40
132S-4	5.5	1440	11.7	85.7	0.83	36.5	7.0	2.3	2.3	1.4	71	76	60
132M-4	7.5	1440	15.6	87.0	0.84	49.8	7.0	2.3	2.3	1.4	71	76	70
160M-4	11	1460	22.5	88.4	0.84	72	7.0	2.2	2.3	1.4	75	79	110
160L-4	15	1460	30	89.4	0.85	98.2	7.5	2.2	2.3	1.4	75	79	130
180M-4	18.5	1470	36.3	90.0	0.86	120	7.5	2.2	2.3	1.2	76	80	165
180L-4	22	1470	42.9	90.5	0.86	143	7.5	2.2	2.3	1.2	76	80	180
200L-4	30	1470	58	91.4	0.86	195	7.2	2.2	2.3	1.2	79	83	240
225S-4	37	1480	70.2	92.0	0.87	239	7.2	2.2	2.3	1.2	81	85	280
225M-4	45	1480	85.0	92.5	0.87	291	7.2	2.2	2.3	1.1	81	85	310
250M-4	55	1480	103	93.0	0.87	355	7.2	2.2	2.3	1.1	83	86	400
280S-4	75	1480	138	93.6	0.88	484	6.8	2.2	2.3	1.0	86	89	540
280M-4	90	1480	165	93.9	0.88	581	6.8	2.2	2.3	1.0	86	89	620
315S-4	110	1480	201	94.5	0.88	710	6.9	2.1	2.2	1.0	93	96	870
315M-4	132	1480	240	94.8	0.88	852	6.9	2.1	2.2	1.0	93	96	990
315L1-4	160	1480	288	94.9	0.89	1032	6.9	2.1	2.2	1.0	97	100	1050
315L2-4	200	1480	360	94.9	0.89	1290	6.9	2.1	2.2	0.9	97	100	1250
355M1-4	220	1490	390	95.2	0.90	1411	6.9	2.1	2.2	0.9	101	104	1650
355M2-4	250	1490	443	95.2	0.90	1603	6.9	2.1	2.2	0.9	101	104	1750
355L1-4	280	1490	497	95.2	0.90	1796	7.1	2.1	2.2	0.9	101	104	1790
355L2-4	315	1490	559	95.2	0.90	2020	7.1	2.1	2.2	0.8	101	104	1900

Note. Data May Change Without Notice

6-Pole, 1000 r/min Synchronous Speed

380V 50Hz

Motor Type	Rated Power	Rated Speed	Rated Current	Rated Eff.	Power Factor	Rated Torque	I_{st} In	T_{st} Tn	T_{max} Tn	T_{min} Tn	LW	LW	Net Weight
	kW	r/min	A	η %	$\cos \phi$	Nm					dB(A)	dB(A)	
											no load	load	Kg
80M1-6	0.37	890	1.3	62.0	0.70	4.0	4.7	1.9	2.0	1.5	54	61	15
80M2-6	0.55	890	1.8	65.0	0.72	5.9	4.7	1.9	2.1	1.5	54	61	17
90S-6	0.75	910	2.3	69.0	0.72	7.9	4.7	2.0	2.1	1.5	57	64	20
90L-6	1.1	910	3.2	72.0	0.73	11.5	5.3	2.0	2.1	1.3	57	64	23
100L-6	1.5	920	4	76.0	0.75	15.6	5.5	2.0	2.1	1.3	61	68	30
112M-6	2.2	940	5.6	79.0	0.76	22.4	5.5	2.0	2.1	1.3	65	72	38
132S-6	3	960	7.4	81.0	0.76	29.9	6.5	2.1	2.1	1.3	69	76	55
132M1-6	4	960	9.8	82.0	0.76	39.8	6.5	2.1	2.1	1.3	69	76	63
132M2-6	5.5	960	12.9	84.0	0.77	54.7	6.5	2.1	2.1	1.3	69	76	70
160M-6	7.5	970	17.2	86.0	0.77	73.9	6.5	2.0	2.1	1.3	73	80	105
160L-6	11	970	24.5	87.5	0.78	108	6.5	2.0	2.1	1.2	73	80	120
180L-6	15	970	31.6	89.0	0.81	148	7.0	2.0	2.1	1.2	73	80	175
200L1-6	18.5	970	38.6	90.0	0.81	182	7.0	2.1	2.1	1.2	76	82	220
200L2-6	22	970	44.7	90.0	0.83	217	7.0	2.0	2.1	1.2	76	82	235
225M-6	30	980	59.3	91.5	0.84	293	7.0	2.0	2.1	1.2	76	82	300
250M-6	37	980	71.1	92.0	0.86	361	7.0	2.1	2.1	1.2	78	84	370
280S-6	45	980	85.9	92.5	0.86	439	7.0	2.1	2.0	1.1	80	85	480
280M-6	55	980	105	92.8	0.86	536	7.0	2.1	2.0	1.1	80	85	535
315S-6	75	990	142	93.5	0.86	724	6.7	2.0	2.0	1.0	85	90	790
315M-6	90	990	170	93.8	0.86	869	6.7	2.0	2.0	1.0	85	90	880
315L1-6	110	990	207	94.0	0.86	1062	6.7	2.0	2.0	1.0	85	90	997
315L2-6	132	990	245	94.2	0.87	1274	6.7	2.0	2.0	1.0	85	90	1100
355M1-6	160	990	292	94.5	0.88	1544	6.7	1.9	2.0	1.0	92	96	1400
355M2-6	200	990	365	94.5	0.88	1930	6.7	1.9	2.0	0.9	92	96	1750
355L-6	250	990	457	94.5	0.88	2413	6.7	1.9	2.0	0.9	92	96	1950

Note. Data May Change Without Notice

PERFORMANCE PARAMETERS

A-Y3H SERIES

8-Pole, 750 r/min Synchronous Speed

380V 50Hz

Motor Type	Rated Power kW	Rated Speed r/min	Rated Current A	Rated Eff. η %	Power Factor $\cos \phi$	Rated Torque Nm	I_{st} In	T_{st} Tn	T_{max} Tn	T_{min} Tn	LW dB(A) no load	LW dB(A) load	Net Weight Kg
80M1-8	0.18	630	0.9	51.0	0.61	2.8	3.3	1.8	1.9	1.3	52	60	15
80M2-8	0.25	640	1.2	54.0	0.61	3.7	3.3	1.8	1.9	1.3	52	60	17
90S-8	0.37	660	1.5	62.0	0.61	5.4	4	1.8	1.9	1.3	56	64	20
90L-8	0.55	660	2.2	63.0	0.61	8.0	4	1.8	2.0	1.3	56	64	23
100L1-8	0.75	690	2.4	70.0	0.67	10.4	4	1.8	2.0	1.3	59	67	30
100L2-8	1.1	690	3.4	72.0	0.69	15.2	5	1.8	2.0	1.2	59	67	35
112M-8	1.5	690	4.4	74.0	0.70	20.8	5	1.8	2.0	1.2	61	69	40
132S-8	2.2	710	6.0	79.0	0.71	29.6	6	1.8	2.0	1.2	64	72	52
132M-8	3	710	7.8	80.0	0.73	40.4	6	1.8	2.0	1.2	64	72	60
160M1-8	4	720	10.3	81.0	0.73	53.1	6	1.9	2.0	1.2	68	76	90
160M2-8	5.5	720	13.6	83.0	0.74	73.0	6	1.9	2.0	1.2	68	76	105
160L-8	7.5	720	17.8	85.5	0.75	99.5	6	1.9	2.0	1.2	68	76	120
180L-8	11	730	25.5	87.5	0.75	144	6.5	2.0	2.0	1.1	70	78	150
200L-8	15	730	34.1	88.0	0.76	196	6.6	2.0	2.0	1.1	73	80	215
225S-8	18.5	730	41.1	90.0	0.76	242	6.6	1.9	2.0	1.1	73	80	265
225M-8	22	740	47.4	90.5	0.78	284	6.6	1.9	2.0	1.1	73	80	295
250M-8	30	740	63.4	91.0	0.79	387	6.5	1.9	2.0	1.1	75	82	380
280S-8	37	740	77.8	91.5	0.79	478	6.6	1.9	2.0	1.1	76	83	485
280M-8	45	740	94.1	92.0	0.79	581	6.6	1.9	2.0	1.0	76	83	570
315S-8	55	740	111	92.8	0.81	710	6.6	1.8	2.0	1.0	82	88	750
315M-8	75	740	150	93.5	0.81	968	6.2	1.8	2.0	0.9	82	88	810
315L1-8	90	740	178	93.8	0.82	1162	6.4	1.8	2.0	0.9	82	88	1000
315L2-8	110	740	217	94.0	0.82	1420	6.4	1.8	2.0	0.9	82	88	1180
355M1-8	132	740	261	93.7	0.82	1704	6.4	1.8	2.0	0.9	90	95	1500
355M2-8	160	740	315	94.2	0.82	2066	6.4	1.8	2.0	0.9	90	95	1800
355L-8	200	740	387	94.5	0.83	2582	6.4	1.8	2.0	0.9	90	95	1900

Note. Data May Change Without Notice

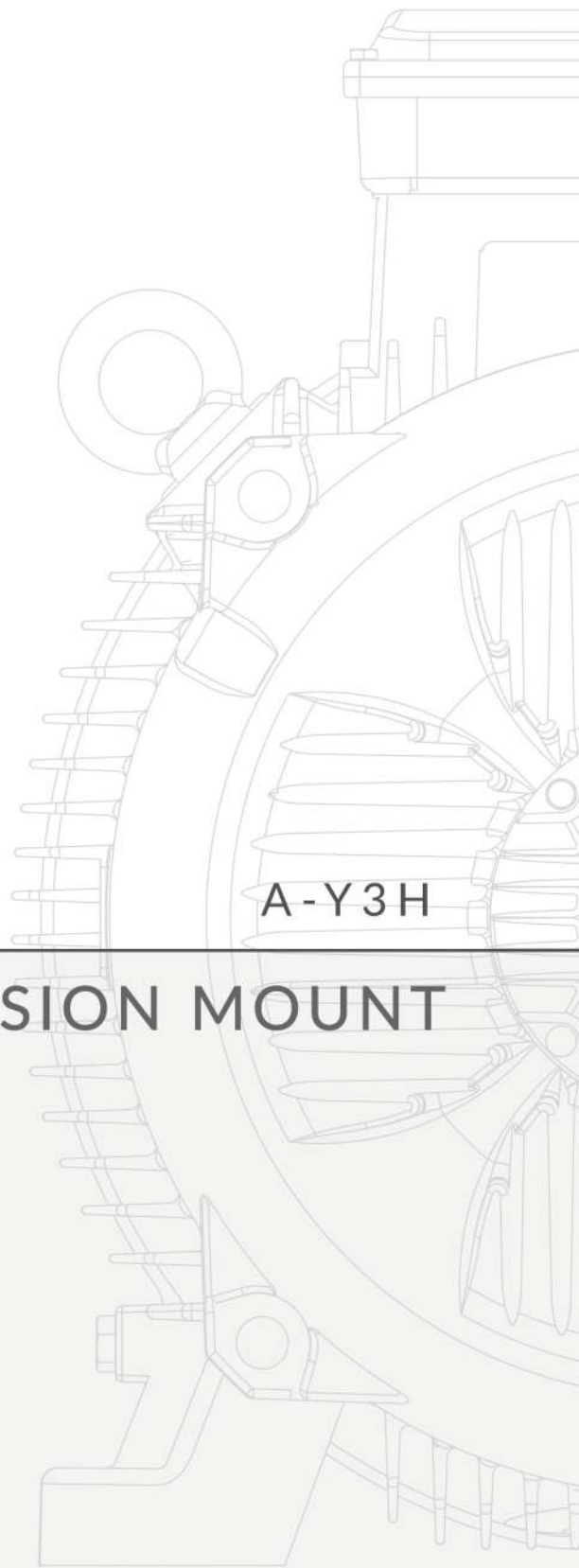

A-Y3H

DIMENSION MOUNT

DIMENSIONS MOUNT

A-Y3H SERIES

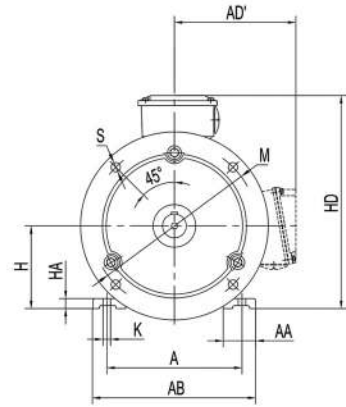
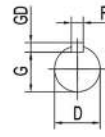
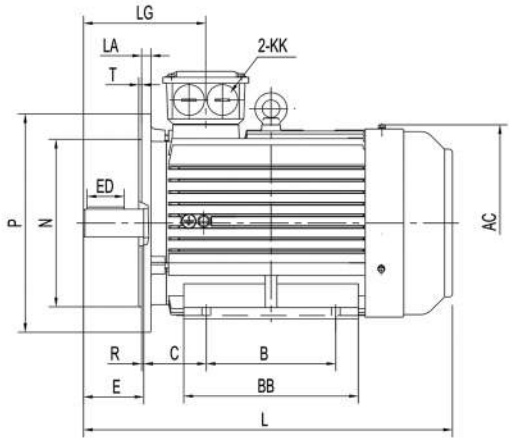

B35

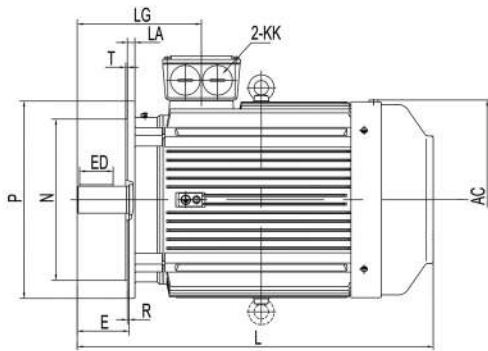

V1

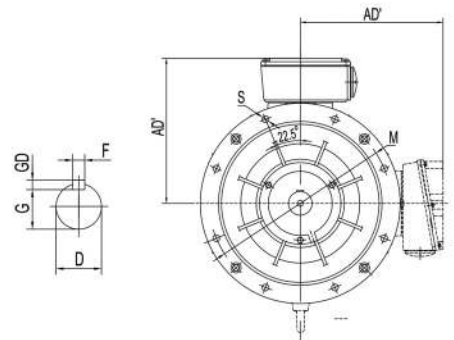
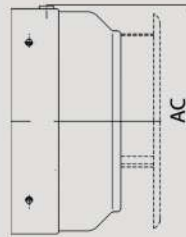

B5 / V1

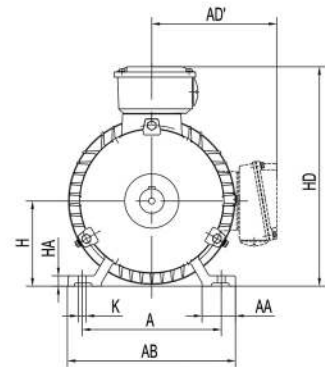
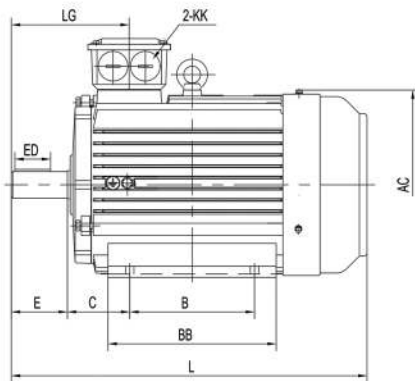

B3

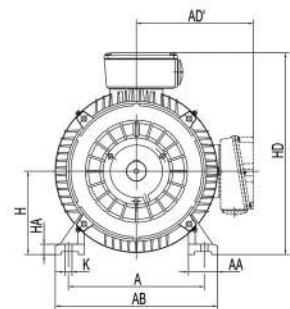
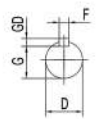
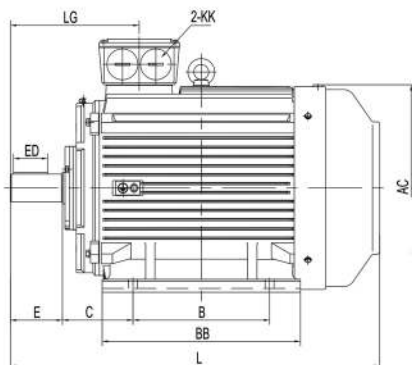

B14

Note. Data May Change Without Notice

Frame	B5																B35											
	A	AA	AB	AC	AD'	B	BB	C	D	E	ED	F	G	GD	H	HA	HD	K	KK	L	LG	LA	M	N	P	S	T	LM
80M	125	34	160	175	150	100	130	50	19	40	22	6	15.5	6	80	10	230	10	M25x1.5	295	106	12	165	130	200	12	3.5	390
90S	140	36	180	190	165	100	135	56	24	50	32	8	20	7	90	12.5	260	10	M25x1.5	320	124	12	165	130	200	12	3.5	430
90L	140	36	180	190	165	125	160	56	24	50	32	8	20	7	90	12.5	260	10	M25x1.5	345	124	14	165	130	200	12	3.5	455
100L	160	40	200	215	170	140	182	63	28	60	40	8	24	7	100	14	275	12	M25x1.5	385	140	14	215	180	250	14.5	4	495
112M	190	45	230	236	195	140	195	70	38	60	40	8	24	7	112	14	310	12	M32x1.5	410	145	14	215	180	250	14.5	4	525
132M	216	52	265	275	215	140	205	89	38	80	56	10	33	8	132	16	350	12	M32x1.5	480	169	14	265	230	300	14.5	4	600
132M	216	52	265	275	215	178	245	89	38	80	56	10	33	8	132	16	350	12	M32x1.5	520	169	15	265	230	300	14.5	4	640
160M	254	65	320	330	265	210	260	108	42	110	80	12	37	8	160	19	425	14.5	M40x1.5	610	270	15	300	250	350	18.5	5	770
160L	254	65	350	330	265	254	305	108	42	110	80	12	37	8	160	19	425	14.5	M40x1.5	655	270	15	300	250	350	18.5	5	815
180M	279	70	350	380	280	241	285	121	48	110	80	14	42.5	9	180	22	440	14.5	M40x1.5	680	277	15	300	250	350	18.5	5	860
180L	279	70	350	380	280	279	325	121	48	110	80	14	42.5	9	180	22	440	14.5	M40x1.5	720	277	17	300	250	350	18.5	5	900
200L	318	80	390	420	315	305	355	133	55	10	80	16	49	10	200	25	505	18.5	M50x1.5	760	298	20	350	300	400	18.5	5	965
225S(4-8P)	356	75	435	465	335	286	350	149	60	140	100	18	53	11	225	28	550	18.5	M50x1.5	825	340	20	400	350	450	18.5	5	1040
225M(2P)	356	75	435	465	335	311	375	149	55	110	80	16	49	10	225	28	550	18.5	M50x1.5	820	310	22	400	350	450	18.5	5	1035
225M(4-8P)	356	75	435	465	335	311	375	149	60	140	100	18	53	11	225	28	550	18.5	M50x1.5	850	340	22	400	350	450	18.5	5	1065
250M(2P)	406	100	485	520	375	349	450	168	60	140	100	18	53	11	250	33	635	24	M63x1.5	925	357	24	500	450	550	18.5	5	1155
250M(4-8P)	406	100	485	520	375	349	450	168	65	140	100	18	58	11	250	33	635	24	M63x1.5	925	357	24	500	450	550	18.5	5	1155
280S(2P)	457	105	550	570	405	368	490	190	65	140	100	18	58	11	280	35	695	24	M63x1.5	970	350	24	500	450	550	18.5	5	1215
280S(4-8P)	457	105	550	570	405	368	490	190	75	140	100	20	67.5	12	280	35	695	24	M63x1.5	990	350	25	500	450	550	18.5	5	1235
280M(2P)	457	105	550	570	405	419	540	190	65	140	100	18	58	11	280	35	695	24	M63x1.5	1025	350	25	500	450	550	18.5	5	1270
280M(4-8P)	457	105	550	570	405	419	540	190	75	140	100	20	67.5	12	280	35	695	24	M63x1.5	1045	350	25	500	450	550	18.5	5	1290
315S(2P)	508	125	630	650	500	406	515	216	65	140	100	18	58	11	315	45	810	28	M63x1.5	1160	387	25	600	550	660	24	6	1435
315M(2P)	508	125	630	650	500	457	625	216	65	140	100	18	58	11	315	45	810	28	M63x1.5	1270	387	25	600	550	660	24	6	1545
315L(2P)	508	125	630	650	500	508	625	216	65	140	100	18	58	11	315	45	810	28	M63x1.5	1270	387	25	600	550	660	24	6	1545
315S(4-8P)	508	125	630	650	500	406	515	216	80	170	130	22	71	14	315	45	810	28	M63x1.5	1190	417	25	600	550	660	24	6	1465
315M(4-8P)	508	125	630	650	500	457	625	216	80	170	130	22	71	14	315	45	810	28	M63x1.5	1300	417	25	600	550	660	24	6	1575
315L(4-8P)	508	120	630	650	500	508	625	216	80	170	130	22	71	14	315	45	810	28	M63x1.5	1300	417	25	600	550	660	24	6	1575
355M(2P)	610	125	735	735	645	560	850	254	75	140	110	20	67.5	12	355	49	1000	28	M63x1.5	1600	420	25	740	680	800	24	6	1950
355L(2P)	610	125	735	735	645	630	850	254	75	140	110	20	67.5	12	355	49	1000	28	M63x1.5	1600	450	25	740	680	800	24	6	1950
355M(4-8P)	610	125	735	735	645	560	850	254	95	170	140	25	86	14	355	49	1000	28	M63x1.5	1630	450	25	740	680	800	24	6	1980
355L(4-8P)	610	125	735	735	645	630	850	254	95	170	140	25	86	14	355	49	1000	28	M63x1.5	1630	450	25	740	680	800	24	6	1980

Note. Data May Change Without Notice

BEARING

ALLIANCE MOTORI HEAVY DUTY

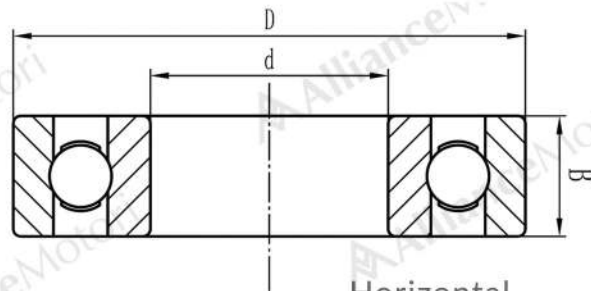

Vertical

Frame Size	DE	NDE	d	D	B
80	6204 ZZ	6204 ZZ	20	47	14
90	6205 ZZ	6205 ZZ	25	52	15
100	6206 ZZ	6206 ZZ	30	62	16
112	6306 ZZ	6306 ZZ	30	72	19
132	6308 ZZ	6308 ZZ	40	90	23
160	6309	6309	45	100	25
180	6311	6311	55	120	29
200	6312	6312	60	130	31
225	6313	6313	65	140	33
250	6314	7314	70	150	35
280 - 2P	6314	7314	70	150	35
280 - 4 - 8P	6317	7317	85	180	41
315 - 2P	6316	7316	80	170	39
315 - 4 - 10P	6319	7319	95	200	45
355 - 2P	6319	7319	95	200	45
355 - 4 - 10P	6322	7322	110	240	50
355L3 - 4P, L2-6P	NU324	7324	120	260	55

Horizontal

Frame Size	DE	NDE	d	D	B
80	6204 ZZ	6204 ZZ	20	47	14
90	6205 ZZ	6205 ZZ	25	52	15
100	6206 ZZ	6206 ZZ	30	62	16
112	6306 ZZ	6306 ZZ	30	72	19
132	6308 ZZ	6308 ZZ	40	90	23
160	6309	6309	45	100	25
180	6311	6311	55	120	29
200	6312	6312	60	130	31
225	6313	6313	65	140	33
250	6314	6314	70	150	35
280 - 2P	6314	6314	70	150	35
280 - 4 - 8P	6317	6317	85	180	41
315 - 2P	6316	6316	80	170	39
315 - 4 - 10P	6319	6319	95	200	45
355 - 2P	6319	6319	95	200	45
355 - 4 - 10P	6322	6322	110	240	50
355L3 - 4P, L2-6P	NU324	6324	120	260	55

BEARING TYPE AND LUBRICATION INTERVAL TABLE

Notes: Motor H80 ~ 132 with sealed bearings need not to grease, motors whose frames dimensions are greater than H160 are equipped with grease filling and draining devices.

For vertical motor, if unspecified, the interval is half of the above value. The above value is based on bearing temperature of 80°C and environment temperature of +25°C. The environment temperature changes will affect the bearing temperature. The interval shall be half every 15°C increased of the bearing temperature, while double the interval every 15°C reduced of bearing temperature.

The standard motor use HTHS grease. Please do not mix other brand and type of grease to avoid damage to the bearing which can be caused by incompatible of different grease.

Frame Size	Frame Size		Grease Amount G	Interval (hour)		
	DE	NDE		<3600rpm	<1800rpm	<1000rpm
160	6309	6309	30	3000	4000	5000
180	6311	6311	50	3000	4000	5000
200	6312	6312	60	3000	4000	5000
225	6313	6313	80	3000	4000	5000
250	6314	6314	80	2000	4000	5000
280 - 2P	6314	6314	80	2000	-	-
280 - 4 - 8P	6317	6317	120	-	4000	5000
315 - 2P	6316	6316	100	2000	-	-
315 - 4 - 10P	6319	6319	120	-	2000	4000
355 - 2P	6319	6319	120	1000	-	-
355 - 4 - 10P	6322	6322	220	-	2000	4000
355L3 - 4P, L2-6P	Nu324	6324	240	-	2000	4000

Note. Data May Change Without Notice

OIL SEALING



Frame Size	Type	d	D	h	H
80	RB20*35*4.0	Ø20	Ø35	3	6
90	RB25*40*4.0	Ø25	Ø40	3	6
100	RB30*47*4.5	Ø30	Ø47	3.5	6
112	RB30*47*4.5	Ø30	Ø47	3.5	6
132	RB40*57*4.5	Ø40	Ø57	3.5	6.5
160	RB45*62*4.5	Ø45	Ø62	3.5	6.5
180	RB55*75*5.5	Ø55	Ø75	4.5	6.5
200	RB60*80*5.5	Ø60	Ø80	4.5	6.5
225	RB65*85*5.5	Ø65	Ø85	4.5	8
250	RB70*90*5.5	Ø70	Ø90	4.5	8
280-2	RB70*90*5.5	Ø70	Ø90	4.5	8
280-4	RB85*105*5.5	Ø85	Ø105	4.5	8
315-2	RB80*100*5.5	Ø80	Ø100	4.5	8
315-4	RB95*115*5.5	Ø95	Ø115	4.5	8
355-2	RB95*115*5.5	Ø95	Ø115	4.5	8
355-4	RB110*130*5.5	Ø110	Ø130	4.5	8

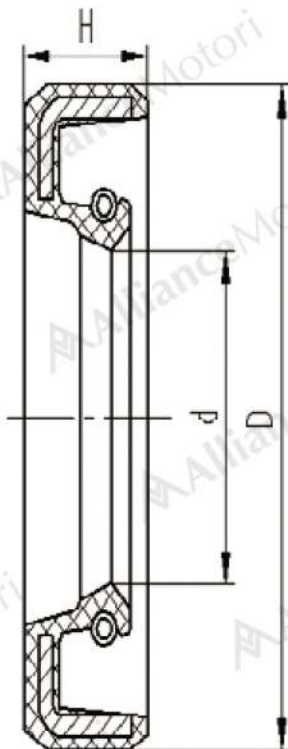



Frame Size	Type	d	D	H
80	(F)B20X42X5	Ø20	Ø42	5
90	(F)B25X47X5	Ø25	Ø47	5
100	(F)B30X52X7	Ø30	Ø52	7
112	(F)B30X52X7	Ø30	Ø52	7
132	(F)B40X62X5	Ø40	Ø62	5
160	(F)B45X70X8	Ø45	Ø70	8
180	(F)B55X80X8	Ø55	Ø80	8
200	(F)B60X85X8	Ø60	Ø85	8
225	(F)B65X90X10	Ø65	Ø90	10
250	(F)B70X95X10	Ø70	Ø95	10
280-2	(F)B70X95X10	Ø70	Ø95	10
280-4.6.8	(F)B85X110X12	Ø85	Ø110	12
315-2	(F)B80X105X10	Ø80	Ø105	10
315-4.6.8	(F)B95X120X12	Ø95	Ø120	12
355-2	(F)B95X120X12	Ø95	Ø120	12
355-4.6.8	(F)B110X140X12	Ø110	Ø140	12
355L3-4P, L2-6P	(F)B120X150X12	Ø120	Ø150	12



Note. Data May Change Without Notice

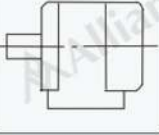
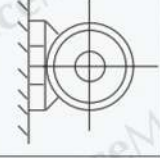

THE MOUNTING ARRANGEMENTS

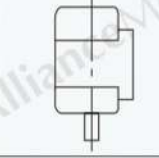
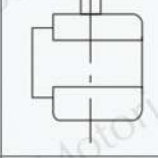
A-Y3H SERIES

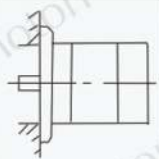
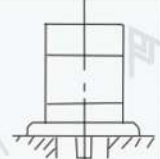
The Mounting arrangements of the motors comply with IEC34-7 Recommendation. Three are four basic arrangements shown as the following tables and figures.

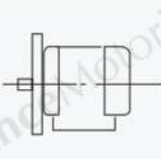
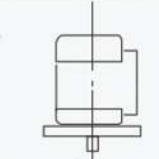
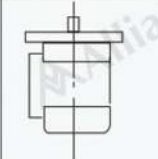
Fundamental arrangement	B3					
Mounting arrangement	B3	B6	B7	B8	V5	V6
Diagram						
Range of Manufacture (framesize)	56-400			56-160		

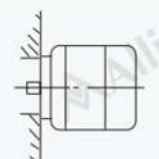
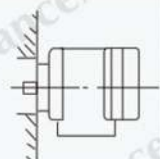
Fundamental arrangement	B5			B35		
Mounting arrangement	B5	V1	V3	B35	V15	V36
Diagram						
Range of Manufacture (framesize)	56-280	56-355	56-160	56-400	56-160	

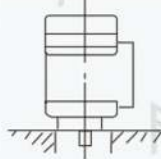
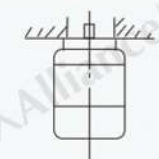
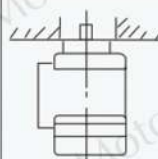
Fundamental arrangement	B14					
Mounting arrangement	B14	B34	V18	V58	V19	V69
Diagram						
Range of Manufacture (framesize)	56-132					

Note. Data May Change Without Notice



www.alliance-gear.com

Authorized Dealer

The information provided in this catalogue contains descriptions or characteristics of performance which in case of actual use do not always apply as described or which may change as a result of further development of the products. An obligation to provide the respective characteristics shall only exist if expressly agreed in the terms of contract. Availability and technical specifications are subject to change without notice.