

TECO

AEEB , AEVB , Series

High efficiency, IP55
three-phase cage induction motors

Frame size 63 to 315M
0.25 to 250 HP
IEC dimension



PT. Teco Multiguna Elektro

Office

Jl. Bandengan Utara No. 83/2-3, Jakarta 14440 - Indonesia
P.O.Box 4967 JKT 10049
Telp. : (62-21) 6622201, 6696985, 6615782, 6695024
Faks. : (62-21) 6697029, 6615783
e-mail : marketing@teco-indonesia.com

Branch Office

Jl. Berbek Industri II No. 21 Sidoarjo 60293
(Kawasan Rungkut Industri Surabaya)
Telp. : (62-31) 8431952, 8434224, 8417399 Faks.: (62-31) 8436672
e-mail : sby-sales@teco-indonesia.com

Representative Office

Kompleks Semarang Indah C-XII No. 5 Semarang Barat 50144
Telp. : (62-24) 7612310 Faks.: (62-24) 7612363

Factory

Jl. Mayor Oking Km. 2,7 - Gunung Putri, Citeureup 16961
Telp. : (62-21) 875-3401/3405, 8754982 Faks.: (62-21) 8752843

www.teco-indonesia.com

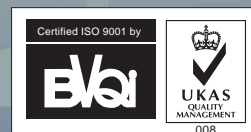

Certificate No. 167861

Performance Data



Motor types AEED and AEVB, Class F insulation, 380/ 415V - 50HZ

Output HP	KW	Full Load Speed (RPM)	Frame Size	% Efficiency			% Power Factor			Current (A)		Current (A)		Torque			Rotor GD ² Kgm ²	Approx Weight AEED Kg	Approx Weight AEVB Kg	
				Full Load	3/4 Load	1/2 Load	Full Load	3/4 Load	1/2 Load	Full Load	Locked Rotor	Full Load	Locked Rotor	Full Load	Locked Rotor	Pull Up				Pull Out
				380 Volts		415 Volts		Kg-m	% FLT	% FLT	% FLT									
0.25	0.18	2740	63	61	59.5	55	77.5	69	57	0.60	2.6	0.55	2.4	0.066	335	335	340	0.0019	8	9
		1350	63	63.5	63	58	70	61	49	0.64	2.6	0.59	2.4	0.134	260	260	260	0.0025	9.5	10.5
		910	71	61	57	50	64	55	44	0.73	2.6	0.67	2.4	0.199	260	260	280	0.0073	12	13
		705	80	52	48	39	47	41	34	1.16	3.5	1.06	3.2	0.257	360	350	370	0.0010	16.5	17.5
0.5	0.37	2800	71	75	74	70	85	78	64	0.88	5.3	0.81	4.8	0.130	320	290	310	0.0025	12	13
		1390	71	67	65	59	70	60	48	1.21	5.3	1.11	4.8	0.261	265	245	270	0.0049	12	13
		920	80	66	64	58	67.5	59	46	1.27	5.3	1.17	4.8	0.394	230	215	240	0.0088	16	17
0.75	0.55	700	90S	64.5	62	55.5	62	53	43	1.42	5.8	1.30	5.3	0.518	190	180	250	0.0173	20.5	22
		2780	71	73	72	68	83	75	62.5	1.4	7.9	1.28	7.2	0.196	300	260	280	0.0025	12.5	13.5
		1405	80	71.5	70.5	65	74	65	52	1.61	8.4	1.47	7.7	0.387	260	240	280	0.0072	14	15
1	0.75	910	80	68	68	63	72	62	49	1.74	6.3	1.59	5.8	0.598	230	210	230	0.0115	17	18
		690	90L	70	70	66	70	61	49	1.74	6.3	1.59	5.8	0.789	180	145	205	0.0228	25	26.5
		2785	80	76.5	77	75.5	88	81.5	70	1.68	11	1.54	9.6	0.261	250	230	270	0.0048	14.5	15.5
1.5	1.1	1400	80	74	73	69	77	68	54	1.99	11	1.82	10	0.518	260	250	280	0.0088	16	17
		935	90S	74	73	69	71	62	49	2.16	11	1.98	10	0.776	200	185	240	0.0173	21.5	23
		690	100L	68	67	61	66	58	46.5	2.53	11	2.31	10	1.052	190	170	230	0.0326	32	33.5
1.5	1.1	2780	80	78	79	77.5	88.5	83	72.5	2.46	16	2.26	14	0.392	275	250	280	0.0060	17.5	18.5
		1400	90S	74	74	70	79	71	58.5	2.91	16	2.66	14	0.778	210	190	250	0.0137	19.5	21
		935	90L	75	74	69	68.5	60	47	3.31	17	3.03	15	1.164	230	215	270	0.0228	25	26.5
2	1.5	690	100L	73.5	73.5	71	67.5	60	48	3.43	16	3.14	14	1.578	210	180	220	0.0457	36	37.5
		2820	90S	81	81.5	80.5	88	83	73	3.18	20	2.91	18	0.515	260	240	270	0.0099	21.5	23
		1405	90L	76.5	77	74	81	73.5	61	3.66	21	3.35	19	1.033	220	190	250	0.0173	23.5	25
3	2.2	925	100L	75	74	71	75.5	67.5	54	4	21	3.66	19	1.569	200	190	230	0.0325	33	34.5
		700	112M	71	70	65	67	58	46	4.77	21	4.37	19	2.074	185	160	240	0.0647	41	43
		2845	90L	83	84	83	89	85	77	4.6	31	4.21	28	0.765	240	240	290	0.0144	26.5	28
4	3	1425	100L	81	80.5	78.5	82.5	76	63	5.08	34	4.66	31	1.528	250	215	270	0.0325	32	33.5
		950	112M	80.5	80	77.5	76.5	69	56	5.53	34	5.06	31	2.292	190	150	250	0.0584	41	43
		710	132S	81.5	81.5	80	74	66	53	5.64	29	5.17	27	3.067	215	200	250	0.1379	62	65
4	3	2845	100L	84.5	85	84.5	88.5	84.5	76.5	6.06	43	5.55	40	1.021	310	280	320	0.0226	35	36.5
		1430	100L	83.5	83	80.5	82	75.5	63	6.62	49	6.06	45	2.030	330	285	340	0.0455	36	37.5
		950	132S	83	82.5	81	79	73.5	63	6.92	42	6.33	39	3.056	210	200	275	0.1248	60	63
5	3.7	715	132M	82.5	81.5	78	67	58	46	8.20	48	7.51	44	4.061	250	235	300	0.1800	75	78
		2865	112M	85.5	86.5	84.5	90	87	79	7.36	63	6.74	58	1.268	240	200	320	0.0418	44	46
		1440	112M	84.5	84	82.5	83.5	76.5	65	8.03	63	7.35	58	2.523	220	200	290	0.0645	43	45
5.5	4	955	132M	80.5	81	77	75.5	65.5	53.5	9.32	63	8.53	58	3.804	180	150	230	0.1511	65	68
		720	160M	81	81	80	72	64	53	9.64	56	8.83	51	5.046	200	180	260	0.3434	107	115
		2865	112M	86	86.5	86	91	88.5	82.5	7.97	61	7.30	56	1.393	290	270	330	0.0418	44	46
7.5	5.5	1440	112M	85	84.5	83	82	77	65	8.95	63	8.19	58	2.772	250	230	310	0.0645	43	45
		955	132M	83	82.5	81	78	71	59	9.63	58	8.82	53	4.180	210	200	280	0.1511	65	68
		720	160M	84.5	84	81.5	71	62.5	50	10.4	56	9.51	51	5.545	200	180	270	0.3434	107	115
10	7.5	2905	132S	87	87	86	88	85	79	11.1	74	10.1	67	1.874	205	190	260	0.0632	65	68
		1445	132S	86	85	83.5	82.5	76	64	12	79	11	72	3.767	240	200	280	0.1029	63	66
		960	132M	84.5	84	82	77	71	58	13.1	84	12	77	5.671	250	245	325	0.2167	80	84
15	11	720	160M	85.5	85.5	83	78	70.5	58	12.7	76	11.7	69	7.561	200	180	270	0.4831	127	135
		2900	132S	88.5	89	88	89	87	82	14.4	95	13.2	87	2.503	240	190	260	0.0753	70	73
		1450	132M	88	88	86.5	85	80	70	15.2	111	13.9	101	5.006	275	220	300	0.1421	77	80
15	11	970	160M	88	87.5	86.5	79	72	61	16.3	110	14.9	101	7.483	270	230	320	0.3993	114	122
		720	160L	86	86.5	85	74.5	66.5	60	17.7	101	16.2	93	10.08	200	180	270	0.5864	145	153
		2940	160M	89	88.5	88	89	86.5	76.5	21.5	153	19.7	140	3.703	215	180	295	0.1474	107	115
15	11	1465	160M	89.5	89	88	86.5	82.5	74	22	153	20.1	140	7.432	235	190	280	0.2955	115	123
		970	160L	88.5	88.5	86.5	83	77	66.5	23.2	163	21.2	149	11.23	275	230	300	0.5864	143	151
		725	180LC	89	89	87.5	79	73	62	24.2	153	22.2	140	15.02	200	190	250	1.2286	198	206

Note :

(1) For ampere values of other voltage motors, multiply the 415 volt values by the following factors:

Voltage	200	220	346	365	400	420	440	500	550
Factor	2.08	1.89	1.2	1.13	1.04	0.99	0.94	0.83	0.75

(2) Data are subject to revisions without notice.

Motor types AEEB and AEVB, Class F insulation, 380/ 415V - 50HZ

Output		Full Load Speed (RPM)	Frame Size	% Efficiency			% Power Factor			Current (A)		Current (A)		Torque			Rotor GD ² Kgm ²	Approx Weight AEEB Kg	Approx Weight AEVB Kg	
HP	KW			Full Load	3/4 Load	1/2 Load	Full Load	3/4 Load	1/2 Load	Full Load	Locked Rotor	Full Load	Locked Rotor	Full Load	Locked Rotor	Pull Up				Pull Out
20	15	2925	160M	90.5	90.5	90	91	89.5	87	27.5	184	25.2	169	4.963	225	185	275	0.1833	122	130
		1460	160L	90	90	88.5	86	81.5	73	29.3	205	26.8	188	9.943	240	200	280	0.3787	132	140
		965	180LC	90	91	91	85	83	76	29.7	174	27.2	159	15.04	210	155	230	1.2286	210	218
		725	200LC	89.5	89.5	88	77	70.5	59	32.8	200	30.1	183	20.02	200	180	240	1.6071	274	284
25	18.5	2925	160L	91.5	91.5	91	92	90	87	33.7	253	30.8	231	6.204	250	200	290	0.2372	138	146
		1455	180MC	91	91.5	91	86	83	78	36.2	226	33.2	207	12.47	200	180	230	0.5696	172	180
		975	200LC	91	91.5	90.5	83.5	80	70	37.3	242	34.1	222	18.61	210	190	250	1.6043	270	280
		730	225SC	90	90.5	89.5	78	74	64	40.3	211	36.9	193	24.86	185	150	200	2.0931	310	325
30	22	2940	180MA	92	92	91	90	87	81.5	41.1	284	37.6	260	7.407	220	190	270	0.2830	185	193
		1460	180LC	91.5	91.5	91.5	86.5	83.5	76.5	42.9	284	39.3	260	14.91	215	180	260	0.7427	205	213
		975	200LC	92.5	92.5	92	83.5	80.5	73	44	284	40.3	260	22.33	225	200	250	1.9118	282	292
		730	225MC	91	91	90	78.5	72	53	47.6	253	43.6	231	29.83	200	175	220	2.4420	340	360
40	30	2960	200LA	91.5	90.5	88.5	85.5	82	71	58	405	53.1	371	9.809	195	160	300	0.5211	270	280
		1470	200LC	92.5	92.5	92	86.5	84	77	56.6	400	51.9	366	19.75	230	180	260	1.2671	278	288
		980	225MC	92	91.5	89.5	81.5	77	67.5	60.4	368	55.3	337	26.63	220	190	240	2.3257	345	365
		730	250SC	91.5	91	90	78.5	72	62.5	63.2	384	57.8	352	39.77	200	170	230	3.4696	410	435
50	37	2955	200LA	92	91.5	90	88.5	86	82	69.6	453	63.7	414	12.28	180	145	260	0.6326	291	301
		1475	225SC	92.5	92.5	92	85	81.5	75.5	72.1	453	66	414	24.61	200	175	250	1.6490	327	342
		975	250SC	92	92	91.5	86	83	75	71.6	453	65.5	414	37.22	205	170	230	3.3734	407	427
		730	250MC	91.5	91.5	91	80	74	65	77.4	453	70.8	414	49.72	200	170	230	4.5652	475	495
60	45	2945	225MA	92	91.5	90	91.5	80.5	87.5	80.7	511	73.9	467	14.79	140	125	255	1.0743	343	362
		1470	225MC	92.5	92.5	92	85.5	83.5	77	86	511	78.7	467	29.63	190	160	230	1.7315	351	371
		975	250MC	92.5	92	91.5	84.5	81.5	74	87.1	558	79.7	511	44.67	220	160	240	3.8292	440	460
		725	280SC	92	91	90.2	80	74	66	92.8	552	85	505	60.5	140	120	210	8.4	640	700
75	55	2965	250SA	92.5	92	90	89	85.5	81	103	758	94.6	694	18.36	165	160	340	1.4098	452	472
		1475	250SC	93.5	93	91.5	89	87.5	83	102	684	93.5	627	39.91	200	150	280	3.6322	475	495
		970	280SC	92.4	92	91	84	80	74	108	683	99	625	55.2	145	125	220	7.0	610	670
		730	280MC	92.4	92	91	80	74	66	112	677	103	620	73.4	135	116	210	10.0	680	740
100	75	2955	250MA	93	92.5	91	90	89	86	136	926	124	848	24.56	150	130	310	1.6784	525	545
		1475	250MC	94	94	93	93.5	94	92.5	129	979	119	896	49.21	180	160	280	4.5039	550	570
		975	280MC	93	92.4	91	85.5	81.5	74	143	928	131	850	74.9	140	120	210	10.0	710	790
		730	315SC	93	92.4	91	80	75.5	68	153	928	140	850	100	135	116	210	19.1	840	920
125	90	2950	280SA	92.4	91	89.5	89.5	87.5	85.5	165	1119	151	1025	29.7	130	130	220	2.7	600	660
		1475	280SC	93	91.7	90.2	87.5	84	80	168	1119	154	1025	59.4	145	123	220	7.0	660	720
		975	315SC	93	92.4	91	85.5	81.5	74	171	1114	157	1020	89.9	140	120	210	15.7	870	950
		730	315MC	93	93	91.7	80	75.5	68	183	1114	168	1020	120	125	110	210	23.9	1020	1120
150	110	2955	280MA	92.4	91	90.2	89.5	87.5	85.5	202	1300	185	1190	36.3	120	120	210	3.6	700	770
		1480	280MC	93	91.7	89.5	87.5	85.5	80	205	1300	188	1190	72.4	125	108	210	8.7	720	800
		975	315MC	93	92.4	91	85.5	81.5	74	210	1300	192	1190	100	120	104	210	19.0	1000	1100
175	132	2955	315SA	93	91.7	90.2	90.2	88.5	85.5	239	1562	219	1430	43.5	140	120	210	6.3	920	1010
		1480	315SC	93.6	92.4	90.2	88.5	85.5	81.5	242	1562	222	1430	86.9	125	106	210	11.3	920	1010
		975	315MC	93.6	93.6	92.4	85.5	81.5	74	250	1562	229	1430	132	120	102	210	21.5	1100	1210
200	150	2960	315MA	93	91.7	90.2	90.2	88.5	85.5	272	1775	249	1625	49.4	140	120	210	7.2	1040	1150
		1480	315MC	93.6	92.4	90.2	88.5	85.5	81.5	275	1775	252	1625	98.7	110	96	210	14.3	1030	1130
250	185	2960	315MA	93	91.7	90.2	90.2	88.5	85.5	335	2190	307	2005	60.9	150	130	210	7.3	1090	1200
		1480	315MB	93.6	92.4	90.2	88.5	88.5	81.5	340	2190	311	2005	122	110	96	210	14.3	1070	1180

Note :

(1) For ampere values of other voltage motors, multiply the 415 volt values by the following factors:

Voltage	200	220	346	365	400	420	440	500	550
Factor	2.08	1.89	1.2	1.13	1.04	0.99	0.94	0.83	0.75

(2) Data are subject to revisions without notice.

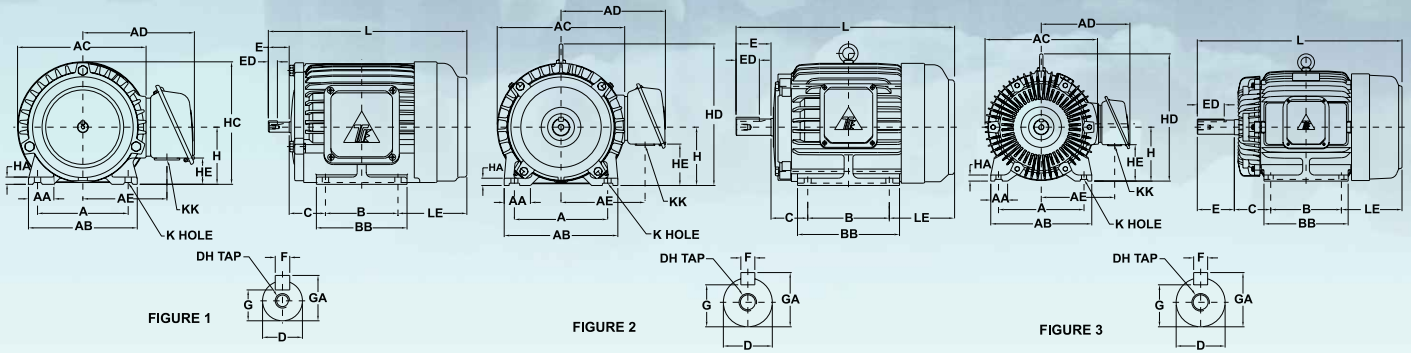

Output (HP)				Frame Size	Fig. No.	Fixing							Shaft				
2P	4P	6P	8P			A	AB	B	BB	C	H	K	D	E	F	G	GA
0.25	0.25	-	-	63	1	100	120	80	100	40	63	7	11j6	23	-	10	-
0.5 / 0.75	0.5	0.25	-	71	1	112	140	90	115	45	71	7	14j6	30	5	11	16
1 / 1.5	0.75 / 1	0.5 / 0.75	0.25	80	1	125	155	100	130	50	80	10	19j6	40	6	15.5	21.5
2	1.5	1	0.5	90S	1	140	170	100	130	56	90	10	24j6	50	8	20	27
3	2	1.5	0.75	90L	1	140	170	125	150	56	90	10	24j6	50	8	20	27
4	3 / 4	2	1 / 1.5	100L	2	160	195	140	175	63	100	12	28j6	60	8	24	31
5 / 5.5	5 / 5.5	3	2	112M	2	190	224	140	175	70	112	12	28j6	60	8	24	31
7.5 / 10	7.5	4	3	132S	2	216	250	140	175	89	132	12	38k6	80	10	33	41
-	10	5 / 5.5 / 7.5	4	132M	2	216	250	178	212	89	132	12	38k6	80	10	33	41
15 / 20	15	10	5 / 5.5 / 7.5	160M	3	254	300	210	250	108	160	14.5	42k6	110	12	37	45
25	20	15	10	160L	3	254	300	254	300	108	160	14.5	42k6	110	12	37	45
-	25	-	-	180MC	3	279	355	241	297	121	180	14.5	48k6	110	14	42.5	51.5
-	30	20	15	180LC	3	279	355	279	335	121	180	14.5	48k6	110	14	42.5	51.5

Frame Size	General													Bearings	
	AA	AC	AD	AE	DH	ED	HA	HC	HD	HE	KK	L	LE	DE	NDE
63	28	144	122	93	M4X8	10	8	135	-	28	20	219	76	6201ZZ	6201ZZ
71	35.5	162	132	103	M5X10	14	8	152	-	53	20	250.5	85.5	6202ZZ	6202ZZ
80	35.5	177	157	122	M6X12	25	9	168	-	55	20	282.5	92.5	6204ZZ	6204ZZ
90S	35.5	200	170	135	M8X16	32	10	190	-	65	20	307.5	101.5	6205ZZ	6205ZZ
90L	35.5	200	170	135	M8X16	32	10	190	-	65	20	332.5	101.5	6205ZZ	6205ZZ
100L	45	219	180	145	M10X20	40	12.5	-	243	70	28	374.5	111.5	6206ZZ	6305ZZ
112M	45	238	189	154	M10X20	40	14	-	265	82	28	391.5	121.5	6306ZZ	6306ZZ
132S	45	273	225	180	M12X24	64	16	-	310	83	35	454	145	6308ZZ	6306ZZ
132M	45	273	225	180	M12X24	64	16	-	310	83	35	492	145	6308ZZ	6306ZZ
160M	50	334	263	218	M16X32	80	18	-	377	108	35	608	180	6309ZZ	6307ZZ
160L	50	334	263	218	M16X32	80	18	-	377	108	35	652	180	6309ZZ	6307ZZ
180MC	75	382	305	250	M16X32	80	20	-	421	119	35	672	200	6311ZZ	6310ZZ
180LC	75	382	305	250	M16X32	80	20	-	421	119	35	710	200	6311ZZ	6310ZZ

Note :

- 1 . All dimensions are in mm.
- 2 . Tolerance of shaft centre height H : +0 , -0.5 for frame size 250 and smaller
+0 , -1.0 for frame size 280 and larger
3. Data are subject to revisions without notice.

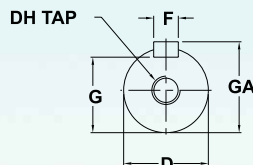
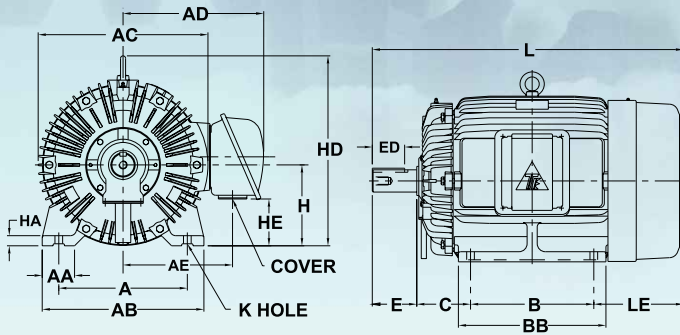

FIGURE 4

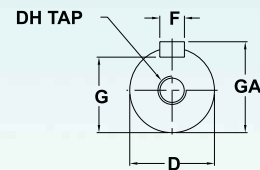
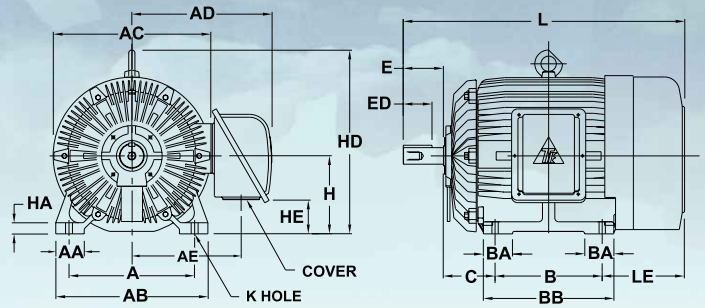

FIGURE 5

Output (HP)				Frame Size	Fig. No.	Fixing							Shaft				
2P	4P	6P	8P			A	AB	B	BB	C	H	K	D	E	F	G	GA
30	-	-	-	180MA	4	279	355	241	297	121	180	14.5	48k6	110	14	42.5	51.5
40 / 50	-	-	-	200LA	4	318	400	305	365	133	200	18.5	55m6	110	16	49	59
-	40	25 / 30	20	200LC	4	318	400	305	365	133	200	18.5	55m6	110	16	49	59
-	50	-	25	225SC	4	356	450	286	350	149	225	18.5	60m6	140	18	53	64
60	-	-	-	225MA	4	356	450	311	375	149	225	18.5	55m6	110	16	49	59
-	60	40	30	225MC	4	356	450	311	375	149	225	18.5	60m6	140	18	53	64
*75	-	-	-	250SA	4	406	500	311	385	168	250	24	60m6	140	18	53	64
-	75	50	40	250SC	4	406	500	311	385	168	250	24	70m6	140	20	62.5	74.5
*100	-	-	-	250MA	4	406	500	349	425	168	250	24	60m6	140	18	53	64
-	100	60	50	250MC	4	406	500	349	425	168	250	24	70m6	140	20	62.5	74.5
*125	-	-	-	280SA	5	457	560	368	445	190	280	24	65m6	140	18	58	69
-	125	75	60	280SC	5	457	560	368	445	190	280	24	80m6	170	22	71	85
*150	-	-	-	280MA	5	457	560	419	495	190	280	24	65m6	140	18	58	69
-	150	100	75	280MC	5	457	560	419	495	190	280	24	80m6	170	22	71	85
*175	-	-	-	315SA	5	508	615	406	490	216	315	28	65m6	140	18	58	69
-	175	125	100	315SC	5	508	615	406	490	216	315	28	85m6	170	22	76	90
*200 / 250	-	-	-	315MA	5	508	615	457	540	216	315	28	65m6	140	18	58	69
-	200	150 / 175	125	315MC	5	508	615	457	540	216	315	28	85m6	170	22	76	90
-	*250	-	-	315MB	5	508	615	457	540	216	315	28	85m6	170	22	76	90

Frame Size	General													Bearings	
	AA	AC	AD	AE	BA	DH	ED	HA	HD	HE	KK	L	LE	Drive End	NDE
180MA	75	382	305	250	-	M16X32	80	20	421	119	35	672	200	6211C3	6211C3
200LA	80	420	374	287	-	M20X40	80	25	469	115	-	770	222	6312C3	6212C3
200LC	80	420	374	287	-	M20X40	80	25	469	115	-	770	222	6312	6212
225SC	90	458	427	326	-	M20X40	110	30	524	84	-	816	241	6313	6213
225MA	90	458	427	326	-	M20X40	80	30	524	84	-	811	241	6312C3	6212C3
225MC	90	458	427	326	-	M20X40	110	30	524	84	-	841	241	6313	6213
250SA	100	510	493	378	-	M20X40	110	36	575	74	-	882.5	263.5	6313C3	6213C3
250SC	100	510	493	378	-	M20X40	110	36	575	74	-	882.5	263.5	6316 (NU216)	6213
250MA	100	510	493	378	-	M20X40	110	36	575	74	-	920.5	263.5	6313C3	6213C3
250MC	100	510	493	378	-	M20X40	110	36	575	74	-	920.5	263.5	6316 (NU216)	6213
280SA	110	577	520	405	110	M20X40	110	36	660	106	-	992	294	6314C3	6314C3
280SC	110	577	520	405	110	M20X40	140	36	660	106	-	1022	294	6318 (NU318)	6316
280MA	110	577	520	405	110	M20X40	110	36	660	106	-	1042	293	6314C3	6314C3
280MC	110	577	520	405	110	M20X40	140	36	660	106	-	1072	293	6318 (NU318)	6316
315SA	115	637	545	430	115	M20X40	110	40	743	136	-	1086	324	6314C3	6314C3
315SC	115	637	545	430	115	M20X40	140	40	743	136	-	1116	324	6320 (NU320)	6316
315MA	115	637	545	430	115	M20X40	110	40	743	136	-	1137	324	6314C3	6314C3
315MC	115	637	545	430	115	M20X40	140	40	743	136	-	1167	324	6320 (NU320)	6316
315MB	115	637	545	430	115	M20X40	140	40	743	136	-	1167	324	6320 (NU320)	6316

Note :

- Output (HP) with mark * is for direct coupling drive only.
- Roller bearings in brackets () are for 6 Pole and 8 Pole motors. For frame sizes 250 through 315, NU series roller bearings can be fitted to the drive end of the 4 Pole motors when higher radial loads are encountered , such as belt drive applications.
- Data are subject to revisions without notice.

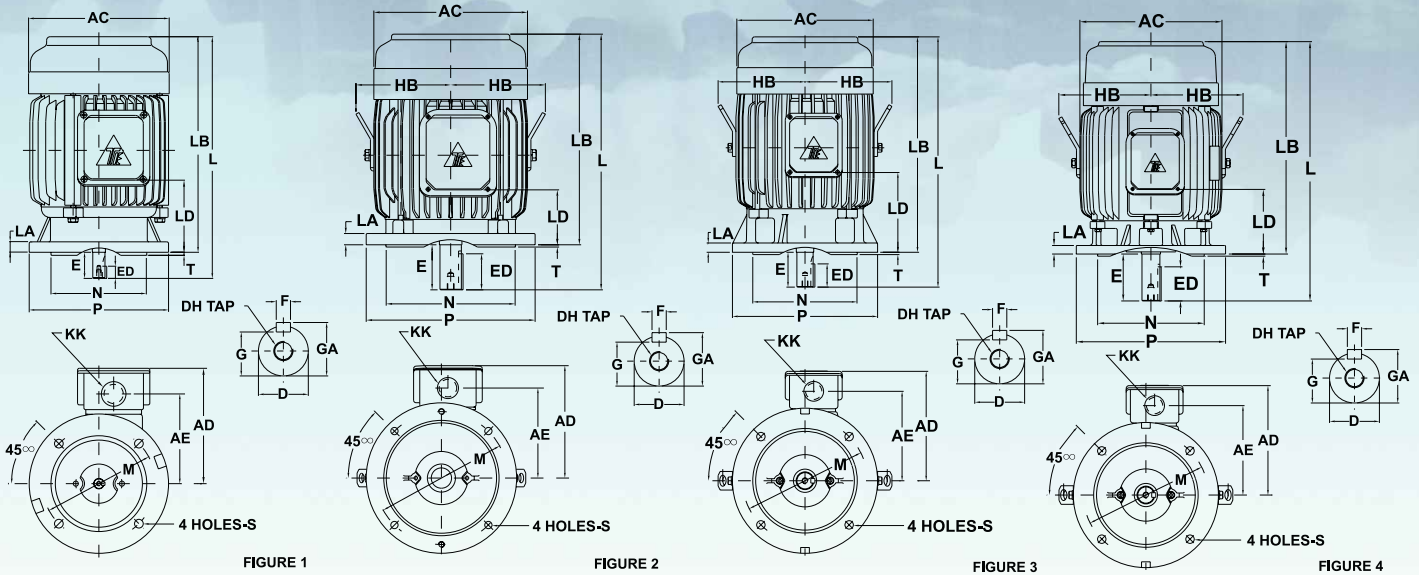

Output (HP)				Frame Size	Fig. No.	Fixing						Shaft				
2P	4P	6P	8P			M	N	P	S	T	LA	D	E	F	G	GA
0.25	0.25	-	-	63	1	130	110	160	10	3.5	12	11j6	23	-	10	-
0.5 / 0.75	0.5	0.25	-	71	1	130	110	160	10	3.5	12	14j6	30	5	11	16
1 / 1.5	0.75 / 1	0.5 / 0.75	0.25	80	2	165	130	200	12	3.5	12	19j6	40	6	15.5	21.5
2	1.5	1	0.5	90S	3	165	130	200	12	3.5	12	24j6	50	8	20	27
3	2	1.5	0.75	90L	3	165	130	200	12	3.5	12	24j6	50	8	20	27
4	3 / 4	2	1 / 1.5	100L	2	215	180	250	14.5	4	16	28j6	60	8	24	31
5 / 5.5	5 / 5.5	3	2	112M	3	215	180	250	14.5	4	16	28j6	60	8	24	31
7.5 / 10	7.5	4	3	132S	2	265	230	300	14.5	4	20	38k6	80	10	33	41
-	10	5 / 5.5 / 7.5	4	132M	2	265	230	300	14.5	4	20	38k6	80	10	33	41
15 / 20	15	10	5 / 5.5 / 7.5	160M	4	300	250	350	18.5	5	20	42k6	110	12	37	45
25	20	15	10	160L	4	300	250	350	18.5	5	20	42k6	110	12	37	45
-	25	-	-	180MC	4	300	250	350	18.5	5	20	48k6	110	14	42.5	51.5
-	30	20	15	180LC	4	300	250	350	18.5	5	20	48k6	110	14	42.5	51.5

Frame Size	General										Bearings	
	AC	AD	AE	DH	ED	HB	KK	L	LB	LD	DE	NDE
63	144	123	93	M4X8	10	-	20	248	225	74	6202ZZ	6201ZZ
71	162	133	103	M5X10	14	-	20	277.5	247.5	82	6202ZZ	6202ZZ
80	177	159	122	M6X12	25	-	20	282	242	55	6204ZZ	6204ZZ
90S	200	170	135	M8X16	32	-	20	346.5	296.5	100	6205ZZ	6205ZZ
90L	200	170	135	M8X16	32	-	20	371.5	321.5	113	6205ZZ	6205ZZ
100L	219	180	144.5	M10X20	40	140	28	374.5	314.5	88	6206ZZ	6305ZZ
112M	238	189	154	M10X20	40	150	28	431	371	135	6306ZZ	6306ZZ
132S	273	224	179.5	M12X24	64	169	35	454	374	97	6308ZZ	6306ZZ
132M	273	224	179.5	M12X24	64	169	35	492	412	116	6308ZZ	6306ZZ
160M	334	263	218	M16X32	80	217	35	608	498	151	6309ZZ	6307ZZ
160L	334	263	218	M16X32	80	217	35	652	542	173	6309ZZ	6307ZZ
180MC	382	305	250	M16X32	80	241	35	672	562	170	6311ZZ	6310ZZ
180LC	382	305	250	M16X32	80	241	35	710	600	189	6311ZZ	6310ZZ

Note :

1. All dimensions are in mm.
2. Tolerance of N : h7
3. Data are subject to revisions without notice.

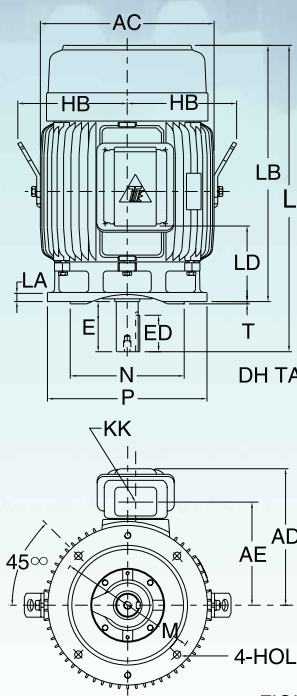

FIGURE 5

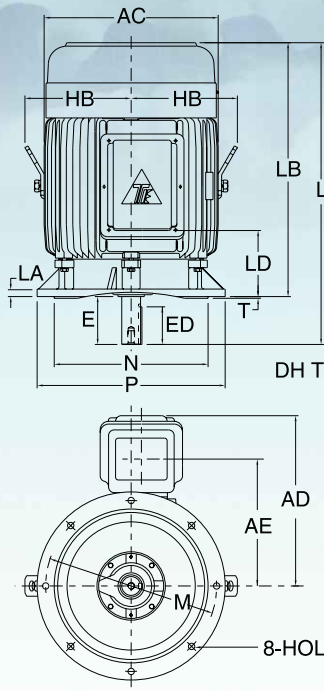

FIGURE 6

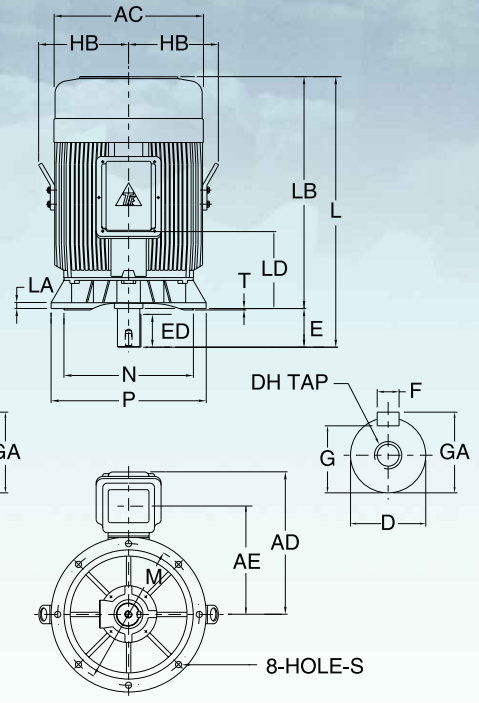

FIGURE 7

Output (HP)				Frame Size	Fig. No.	Fixing						Shaft				
2P	4P	6P	8P			M	N	P	S	T	LA	D	E	F	G	GA
30	-	-	-	180MA	5	300	250	350	18.5	5	20	48k6	110	14	42.5	51.5
40 / 50	-	-	-	200LA	5	350	300	400	18.5	5	20	55m6	110	16	49	59
-	40	25 / 30	20	200LC	5	350	300	400	18.5	5	20	55m6	110	16	49	59
-	50	-	25	225SC	6	400	350	450	18.5	5	22	60m6	140	18	53	64
60	-	-	-	225MA	6	400	350	450	18.5	5	22	55m6	110	16	49	59
-	60	40	30	225MC	6	400	350	450	18.5	5	22	60m6	140	18	53	64
*75	-	-	-	250SA	6	500	450	550	18.5	5	22	60m6	140	18	53	64
-	75	50	40	250SC	6	500	450	550	18.5	5	22	70m6	140	20	62.5	74.5
*100	-	-	-	250MA	6	500	450	550	18.5	5	22	60m6	140	18	53	64
-	100	60	50	250MC	6	500	450	550	18.5	5	22	70m6	140	20	62.5	74.5
*125	-	-	-	280SA	7	500	450	550	19	5	22	65m6	140	18	58	69
-	125	75	60	280SC	7	500	450	550	19	5	22	80m6	170	22	71	85
*150	-	-	-	280MA	7	500	450	550	19	5	22	65m6	140	18	58	69
-	150	100	75	280MC	7	500	450	550	19	5	22	80m6	170	22	71	85
*175	-	-	-	315SA	7	600	550	660	24	6	25	65m6	140	18	58	69
-	175	125	100	315SC	7	600	550	660	24	6	25	85m6	170	22	76	90
*200 / 250	-	-	-	315MA	7	600	550	660	24	6	25	65m6	140	18	58	69
-	200	150 / 175	125	315MC	7	600	550	660	24	6	25	85m6	170	22	76	90
-	*250	-	-	315MB	7	600	550	660	24	6	25	85m6	170	22	76	90

Frame Size	General										Bearings	
	AC	AD	AE	DH	ED	HB	KK	L	LB	LD	Drive End	NDE
180MA	382	305	250	M16X32	80	241	35	672	562	170.5	6211C3	6211C3
200LA	420	374	287	M20X40	80	260	-	770	660	150	6312C3	6212C3
200LC	420	374	287	M20X40	80	260	-	770	660	150	6312	6212
225SC	458	427	326	M20X40	110	286	-	816	676	105	6313	6213
225MA	458	427	326	M20X40	80	286	-	811	701	105	6312C3	6212C3
225MC	458	427	326	M20X40	110	286	-	841	701	105	6313	6213
250SA	510	493	378	M20X40	110	312	-	882.5	742.5	85.5	6313C3	6213C3
250SC	510	493	378	M20X40	110	312	-	882.5	742.5	85.5	6316 (NU216)	6213
250MA	510	493	378	M20X40	110	312	-	920.5	780.5	104.5	6313C3	6213C3
250MC	510	493	378	M20X40	110	312	-	920.5	780.5	104.5	6316 (NU216)	6213
280SA	580	520	405	M20X40	110	355	-	992	847	197	6314C3	6314C3
280SC	580	520	405	M20X40	140	355	-	1022	847	197	6318 (NU318)	6316
280MA	580	520	405	M20X40	110	355	-	1042	897	247	6314C3	6314C3
280MC	580	520	405	M20X40	140	355	-	1072	897	247	6318 (NU318)	6316
315SA	637	545	430	M20X40	110	383	-	1086	946	251	6314C3	6314C3
315SC	637	545	430	M20X40	140	383	-	1116	946	251	6320 (NU320)	6316
315MA	637	545	430	M20X40	110	383	-	1137	997	301	6314C3	6314C3
315MC	637	545	430	M20X40	140	383	-	1167	997	301	6320 (NU320)	6316
315MB	637	545	430	M20X40	140	383	-	1167	997	301	6320 (NU320)	6316

Note : 1. All dimensions in mm. 2. Tolerance of N : h7 3. Output (HP) with mark* is for direct coupling service only
 4. Roller bearings () are for 6 Pole and 8 Pole motors only. NU bearing can be fitted to 4 Pole 75HP and larger if they are employed in belt drive applications.
 5. Data are subject to revisions without notice.

Type of motor	Totally-enclosed fan-cooled squirrel cage induction motor
Design standards	BS4999 , BS EN 60034 , IEC 60034, Starting Performance Design N
Voltages and frequency	Standard stock available are 220-240/380-415 V / 50HZ for 3HP and below 380-415/660-720V/ 50HZ for 4HP and above Other voltages such as 200V, 346V, 440V , 460V and 60HZ etc can be supplied on request.
Voltage variation	Motors are suitable for operation for continuous operation (S1 duty) within +/- 6% rated voltage.
Time duty	Maximum continuous rating , S1 duty
Cooling method	Self external fan, surface cooling (IC 411)
Method of starting	Full voltage direct on line starting or star-delta starting
Mounting	Horizontal foot mounting (IM 1001 or IM B3) , flange mounting (IM3011 or IM V1)
Stator insulation and temperature rise	Non-hygroscopic class F insulation system, with class B temperature rise (80 degree C rise) by resistance method at 1.0 S.F.
Rotor winding	Squirrel cage, aluminium conductor with end-ring and wafer blades integrally cast.
Environmental conditions	Place : Non-hazardous Ambient temperature : -20 °C to 40 °C Relative humidity : Less than 90% RH (non-condensation) Altitude : Up to 1,000 metres above sea level.
Drive method	Belt service, however 2 Pole & 4Pole 75HP and larger is for coupling drive
Direction of rotation	Standard motors are suitable for operation in either direction of rotation. Direction of rotation of motor can be reversed by interchanging any two of the power lines.
Test procedure	According to BS 4999
External fan	The fan is of polypropylene and designed for bi-directional rotation. Other material fan is available on request.
Fan cover	Pressed steel sheet.
Shaft	Carbon steel , cylindrical single extension with keyway and key
Bearing	Bracket mounting, grease pre-packed shielded ball bearings for frame size 63 through 180L, open bearings for frame size 180MA 2-Pole and 200L through 315M
Lubrication	Mineral oil, Li-base grease (Frame size 63 through 250 use Multitemp SRL , frame size 280 and larger use Shell Alvania R3)
Terminal box	Standard terminal box is pressed steel type for motor frame size 180 and smaller, cast iron T-box for frame size 200 and larger. Terminal box is rotatable in 90 degree increments through 360 degrees. Terminal box is on the right hand side as seen from drive end as standard. For footmounted motors, it can be changed to the left hand side by changing the rotor position.
Painting	Phenolic rust proof base plus lacquer surface finish painting in blue-grey colour (Munsell 7.5BG 4/2)
Nameplate	Stainless steel
Grounding terminal	All motors are provided with an internal grounding terminal in the motor main terminal box. Additional external grounding terminal on the motor frame is provided for frame size 280 and larger.
Eyebolt	Motor of frame size 100 and larger is equipped with eyebolt or lifting lug.
Electromagnetic compatibility	Compliance with European Electromagnetic Compatibility (EMC) directive reference number 89/336/EEC, standard EN 50081-1 1992, for motors up to 450KW
Options available :	1. IP56 , 2. Class H insulation , 3. Multi-speed 4. Anti-condensation heater , 5. PTC thermistor for thermal protection , 6. Special paint finish 7. Corrosion proof 8. Special shaft extension, 9. Inverter duty application 10. Smoke spill duty 11. Grease relief valves for frames down to 100L

We supply a full range of general purpose induction motors, and also produce made-to-order motors to answer special needs ranging up to 100.000 HP 13.8 kv

TECO – Westinghouse

Featuring

- 1 Single phase totally enclosed fan cooled induction motors
- 1 Single phase open protected drip proof induction motors
- 1 Three phase totally enclosed fan cooled induction motors
- 1 Three phase open protected drip proof induction motors
- 1 Eddy current variable speed motors
- 1 Brake motors, DC motors
- 1 Slip ring wound rotor induction motors
- 1 Geared motors, Crane motors
- 1 Kiln use motors
- 1 Marine motors
- 1 Cooling tower motors
- 1 Pole-change motors
- 1 Clutch/brake motors
- 1 Vertical hollow shaft motors
- 1 High voltage motors
- 1 High voltage synchronous motors
- 1 Mills use induction motors
- 1 Explosion proof motors UL Listed
- 1 Increased safety motors
- 1 Non-sparking motors
- 1 High temperature resistant motors
- 1 Inverter duty application motors
- 1 Stepping motors

Other Products

- 1 Frequency inverters
- 1 Generating sets
- 1 Gear reducers
- 1 Electro-mechanics :
- Starters and contactors
- 1 Power transmissions :
- Electro-magnetic clutches/brakes
- Linear actuators
- Ball bearing screws
- 1 Motors Beds & Rail
- 1 Contractor-Overload Relay
- 1 MCCB - Soft Starter
- 1 MMC Panel
- 1 LV & HV Distribution Panel
- 1 System Integrator